

H. FRÖHLICH AG^{TEC}

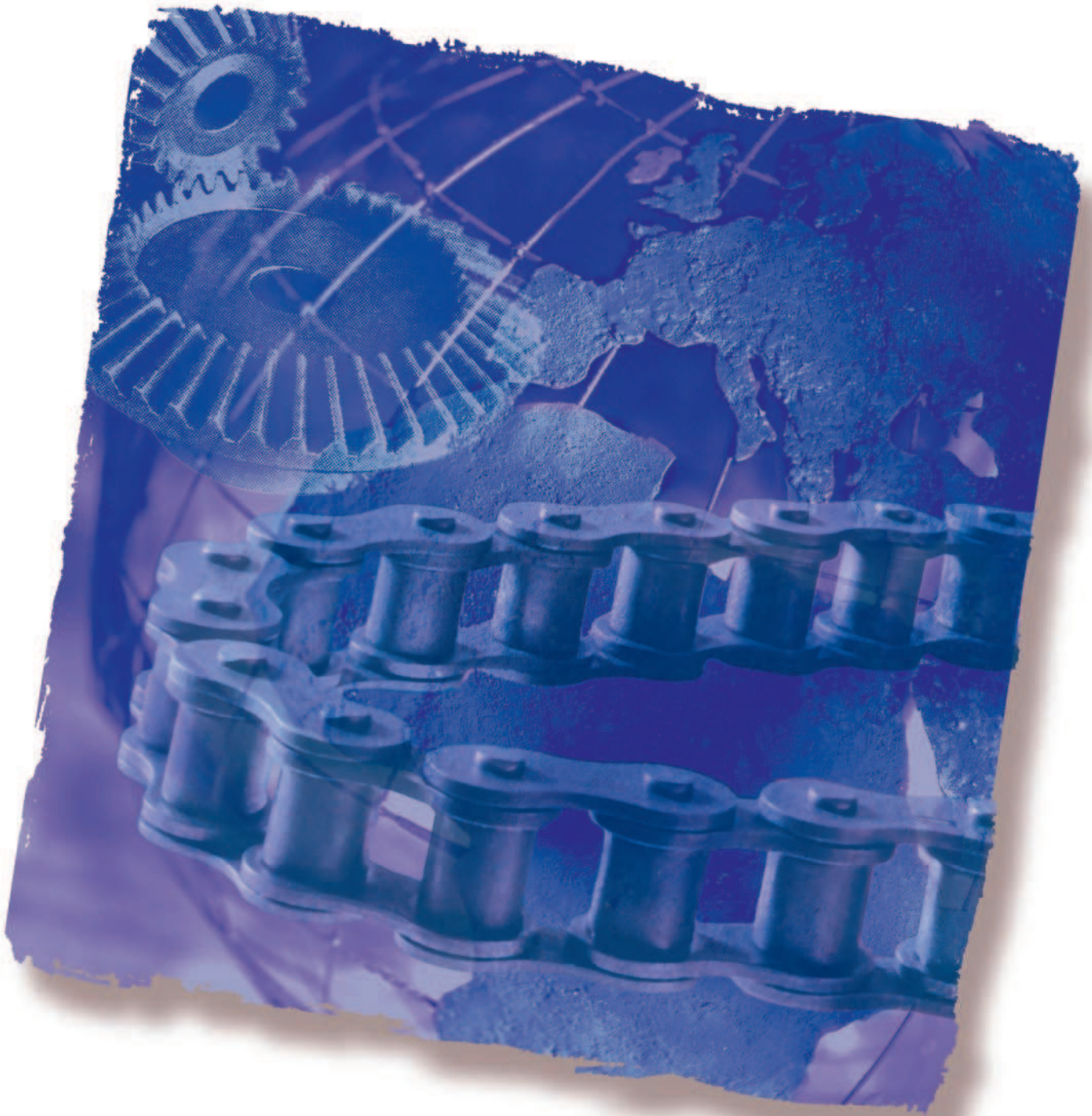

H. FRÖHLICH AG · Industrietechnik · Widenholzstrasse 1 · CH-8304 Wallisellen
Tel. +41 44 910 16 22 · Fax +41 44 910 63 44 · info@h-froehlich-ag.ch · www.h-froehlich-ag.ch

Kettenräder/Kettenradscheiben

Pignons/Roues



Z	d _e	d _p	Simplex			Duplex			Triplex		
			d _m	D ₁	A	d _m	D ₁	A	d _m	D ₁	A
8	15.2	13.06	7	4	10						
9	16.8	14.62	8	5	10						
10	18.3	16.18	9	5	10						
11	19.9	17.75	11	6	10						
12	21.5	19.32	12	6	10						
13	23.0	20.89	14	6	10						
14	24.6	22.47	15	6	10						
15	26.2	24.04	16	6	10						
16	27.8	25.63	18	8	13						
17	29.4	27.20	18	8	13						
18	30.9	28.79	18	8	13						
19	32.5	30.38	18	8	13						
20	34.1	31.96	18	8	13						
21	35.7	33.54	20	8	13						
22	37.3	35.13	20	8	13						
23	38.9	36.72	20	8	13						
24	40.5	38.30	20	8	13						
25	42.0	39.89	20	8	13						
26	43.6	41.48	25	8	15						
27	45.2	43.07	25	8	15						
28	46.8	44.65	25	8	15						
29	48.4	46.25	25	8	15						
30	50.0	47.83	25	8	15						
31	51.6	49.42	30	8	15						
32	53.2	51.01	30	8	15						
33	54.8	52.60	30	8	15						
34	56.3	54.19	30	8	15						
35	57.9	55.78	30	8	15						
36	59.5	57.37	30	8	15						
37	61.1	58.96	30	8	15						
38	62.7	60.54	30	8	15						
39	64.3	62.13	30	8	15						
40	65.9	63.73	30	8	15						

5 x 2,5 mm

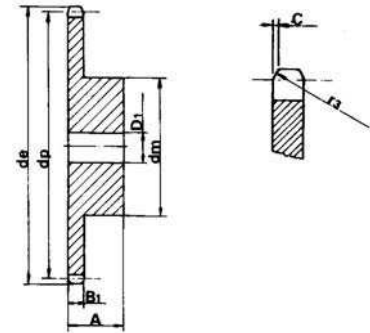

Kettenrad - Pignon mm

r ₃	5
C	0,6
B ₁	2,3

Kette - Chaîne mm

Tlg - Pas	5
Innere Breite - largeur interieur	2,5
Rolle ø - ø Rouleaux	3,2

Z	d _e	d _p	S			Z	d _e	d _p	D		
			D ₁	D ₂	D ₃				D ₁	D ₂	D ₃
8	15.2	13.06	4			44	72.2	70.09	8		
9	16.8	14.62	4			45	73.8	71.68	8		
10	18.3	16.18	4			46	75.4	73.27	8		
11	19.9	17.75	5			47	77.0	74.86	8		
12	21.5	19.32	5			48	78.6	76.45	8		
13	23.0	20.89	5			49	80.2	78.03	8		
14	24.6	22.47	5			50	81.8	79.63	8		
15	26.2	24.04	5			51	83.4	81.22	10		
16	27.8	25.63	6			52	85.0	82.81	10		
17	29.4	27.20	6			53	86.6	84.40	10		
18	30.9	28.79	6			54	88.1	85.97	10		
19	32.5	30.38	6			55	89.7	87.58	10		
20	34.1	31.96	6			56	91.3	89.17	10		
21	35.7	33.54	8			57	92.9	90.76	10		
22	37.3	35.13	8			58	94.5	92.35	10		
23	38.9	36.72	8			59	96.1	93.94	10		
24	40.5	38.30	8			60	97.7	95.53	10		
25	42.0	39.89	8			62	100.9	98.72	12		
26	43.6	41.48	8			64	104.1	101.90	12		
27	45.2	43.07	8			65	105.6	103.49	12		
28	46.8	44.65	8			66	107.2	105.08	12		
29	48.4	46.25	8			68	110.4	108.26	12		
30	50.0	47.83	8			70	113.6	111.44	12		
31	51.6	49.42	8			72	116.8	114.63	12		
32	53.2	51.01	8			75	121.6	119.40	12		
33	54.8	52.60	8			76	123.1	120.99	12		
34	56.3	54.19	8			78	126.3	124.17	12		
35	57.9	55.78	8			80	129.5	127.35	12		
36	59.5	57.37	8			85	137.5	135.31	14		
37	61.1	58.96	8			90	145.4	143.27	14		
38	62.7	60.54	8			95	153.4	151.22	14		
39	64.3	62.13	8			100	161.3	159.18	14		
40	65.9	63.73	8			110	177.2	175.09	14		
41	67.5	65.31	8			114	183.6	181.46	14		
42	69.1	66.91	8			120	193.2	191.01	14		
43	70.6	68.49	8			125	201.1	198.96	14		

5 x 2,5 mm

ab z = 51
depuis z = 51

h = 4 mm
h = 4 mm

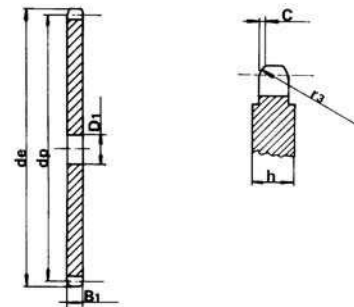

Kettenradscheibe - Roue mm

r ₃	5
C	0,6
B ₁	2,3

Kette - Chaîne mm

Tlg - Pas	5
Innere Breite - largeur interieur	2,5
Rolle ø - ø Rouleaux	3,2

Kettenräder/Kettenradscheiben

Pignons/Roues

Z	d _e	d _p	Simplex		Duplex		Triplex	
			d _m	A	d _m	A	d _m	A
8	18.0	15.67	9.8	5	10			
9	19.9	17.54	11.5	5	10			
10	21.7	19.42	13	6	10			
11	23.6	21.30	14	6	10			
12	25.4	23.18	16	6	10			
13	27.3	25.05	18	8	10			
14	29.2	26.96	20	8	10			
15	31.0	28.86	20	8	10			
16	33.0	30.76	20	8	13			
17	35.0	32.65	20	8	13			
18	36.9	34.55	20	8	13			
19	38.8	36.44	20	8	13			
20	40.7	38.34	20	8	13			
21	42.6	40.25	25	8	13			
22	44.5	42.16	25	8	13			
23	46.4	44.06	25	8	13			
24	48.3	45.96	25	8	13			
25	50.2	47.87	25	8	13			
26	52.1	49.76	30	8	15			
27	54.0	51.67	30	8	15			
28	55.9	53.58	30	8	15			
29	57.8	55.50	30	8	15			
30	59.8	57.42	30	8	15			
31	61.7	59.31	30	8	15			
32	63.6	61.21	30	8	15			
33	65.5	63.11	30	8	15			
34	67.4	65.02	30	8	15			
35	69.3	66.93	30	8	15			
36	71.2	68.84	30	8	15			
37	73.1	70.75	30	8	15			
38	75.0	72.66	30	8	15			
39	76.9	74.57	30	8	15			
40	78.9	76.47	30	8	15			
45	88.5	86.01	40	10	16			
50	98.0	95.55	50	12	20			
57	111.4	108.93	50	12	20			
76	147.6	145.19	60	12	20			

6 x 2,8 mm

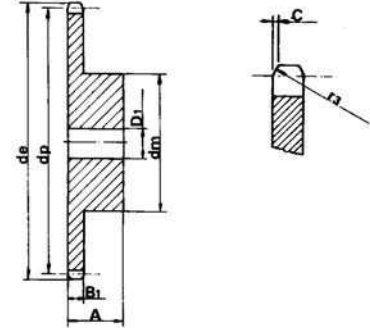

Kettenrad - Pignon

r ₃	6
C	0,7
B ₁	2,6

Kette - Chaîne

Tlg - Pas	6
Innere Breite - largeur interieur	2,8
Rolle ø - ø Rouleaux	4

Z	d _e	d _p	S		D		T	
			D ₁	D ₂	D ₂	D ₃		
8	18.0	15.67	5					
9	19.9	17.54	5					
10	21.7	19.42	6					
11	23.6	21.30	6					
12	25.4	23.18	6					
13	27.3	25.05	8					
14	29.2	26.96	8					
15	31.0	28.86	8					
16	33.0	30.76	8					
17	35.0	32.65	8					
18	36.9	34.55	8					
19	38.8	36.44	8					
20	40.7	38.34	8					
21	42.6	40.25	8					
22	44.5	42.16	8					
23	46.4	44.06	8					
24	48.3	45.96	8					
25	50.2	47.87	8					
26	52.1	49.76	8					
27	54.0	51.67	8					
28	55.9	53.58	8					
29	57.8	55.50	8					
30	59.8	57.42	8					
31	61.7	59.31	8					
32	63.6	61.21	8					
33	65.5	63.11	8					
34	67.4	65.02	8					
35	69.3	66.93	8					
36	71.2	68.84	8					
37	73.1	70.75	8					
38	75.0	72.66	8					
39	76.9	74.57	8					
40	78.9	76.47	8					
41	80.8	78.38	10					
42	82.7	80.28	10					
43	84.7	82.19	10					

Z	d _e	d _p	S		D		T	
			D ₁	D ₂	D ₂	D ₃		
44	86.6	84.10	10					
45	88.5	86.01	10					
46	90.4	87.92	10					
47	92.3	89.93	10					
48	94.2	91.74	10					
49	96.1	93.64	10					
50	98.0	95.55	10					
51	99.9	97.46	12					
52	101.8	99.37	12					
53	103.7	101.27	12					
54	105.6	103.17	12					
55	107.6	105.08	12					
56	109.5	107.00	12					
57	111.4	108.93	12					
58	113.3	110.82	12					
59	115.2	112.71	12					
60	117.1	114.62	12					
62	120.9	118.45	14					
64	124.7	122.27	14					
65	126.6	124.18	14					
66	128.5	126.09	14					
68	132.4	129.91	14					
70	136.2	133.73	14					
72	140.0	137.55	16					
75	145.7	143.28	16					
76	147.6	145.19	16					
78	151.5	149.01	16					
80	155.3	152.82	16					
85	164.8	162.37	16					
90	174.4	171.92	16					
95	183.9	181.47	16					
100	193.5	191.01	16					
110	212.6	210.11	16					
114	220.2	217.75	16					
120	231.7	229.20	16					
125	241.2	238.75	16					

6 x 2,8 mm

ab z = 51
depuis z = 51

h = 4 mm
h = 4 mm

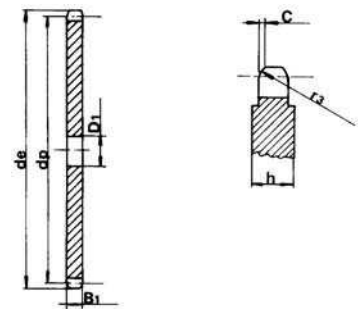

Kettenradscheibe - Roue

r ₃	6
C	0,7
B ₁	2,6

Kette - Chaîne

Tlg - Pas	6
Innere Breite - largeur interieur	2,8
Rolle ø - ø Rouleaux	4

Kettenräder/Kettenradscheiben

Pignons/Roues

Z	d _e	d _p	Simplex			Duplex			Triplex		
			d _m	D ₁	A	d _m	D ₁	A	d _m	D ₁	A
8	38.5	33.18	21	8	14						
9	41.5	37.13	25	8	14						
10	46.2	41.10	28	8	14						
11	49.6	45.07	31	8	16						
12	53.9	49.07	35	8	16						
13	58.4	53.06	39	8	16						
14	62.8	57.07	43	8	16						
15	66.8	61.09	47	8	16						
16	70.9	65.10	50	10	18						
17	74.9	69.11	50	10	18						
18	78.9	73.14	50	10	18						
19	82.9	77.16	50	10	18						
20	88.9	81.19	50	10	18						
21	91.0	85.22	60	12	20						
22	95.0	89.24	60	12	20						
23	99.0	93.27	60	12	20						
24	103.0	97.29	60	12	20						
25	107.1	101.33	60	12	20						
26	111.2	105.36	70	16	20						
27	115.4	109.40	70	16	20						
28	119.4	113.42	70	16	20						
29	123.4	117.46	70	16	20						
30	127.5	121.50	70	16	20						
31	131.5	125.54	70	16	20						
32	135.5	129.56	70	16	20						
33	139.6	133.60	70	16	20						
34	143.6	137.64	70	16	20						
35	147.6	141.68	70	16	20						
36	151.7	145.72	70	16	25						
37	155.7	149.76	70	16	25						
38	159.8	153.80	70	16	25						
39	163.8	157.83	70	16	25						
40	167.8	161.87	70	16	25						

Z	d _e	d _p	S			T
			D ₁	D ₂	D ₃	
8	38.5	33.18	8			
9	41.5	37.13	8			
10	46.2	41.10	8			
11	49.6	45.07	8			
12	53.9	49.07	8			
13	58.4	53.06	8			
14	62.8	57.07	8			
15	66.8	61.09	8			
16	70.9	65.10	10			
17	74.9	69.11	10			
18	78.9	73.14	10			
19	82.9	77.16	10			
20	86.9	81.19	10			
21	91.0	85.22	10			
22	95.0	89.24	10			
23	99.0	93.27	10			
24	103.0	97.29	10			
25	107.1	101.33	10			
26	111.2	105.36	12			
27	115.4	109.40	12			
28	119.4	113.42	12			
29	123.4	117.46	12			
30	127.5	121.50	12			
31	131.5	125.54	12			
32	135.5	129.56	12			
33	139.6	133.60	12			
34	143.6	137.64	12			
35	147.6	141.68	12			
36	151.7	145.72	16			
37	155.7	149.76	16			
38	159.8	153.80	16			
39	163.8	157.83	16			
40	167.8	161.87	16			
41	171.4	165.91	16			
42	175.4	169.95	16			

Z	d _e	d _p	S			T
			D ₁	D ₂	D ₃	
43	179.5	173.99	16			
44	183.5	178.03	16			
45	187.5	182.07	16			
46	191.6	186.10	20			
47	195.6	190.14	20			
48	199.7	194.18	20			
49	203.7	198.22	20			
50	207.8	202.26	20			
51	211.8	206.30	20			
52	215.9	210.34	20			
53	219.9	214.37	20			
54	224.0	218.43	20			
55	228.0	222.46	20			
56	232.1	226.50	20			
57	236.1	230.54	20			
58	240.2	234.58	20			
59	244.2	238.62	20			
60	248.2	242.66	20			
62	256.7	250.75	20			
64	264.8	258.82	20			
65	268.8	262.86	20			
66	272.9	266.90	25			
68	280.9	274.99	25			
70	289.0	283.07	25			
72	297.1	291.16	25			
76	313.3	307.33	25			
78	321.4	315.40	25			
80	329.4	323.48	25			
85	349.7	343.70	25			
90	369.9	363.90	25			
95	390.1	384.10	25			
100	410.3	404.31	25			
110	450.7	444.74	25			
114	466.9	460.90	25			
120	491.2	485.16	25			
125	511.4	505.37	25			

1/2" x 3/16"

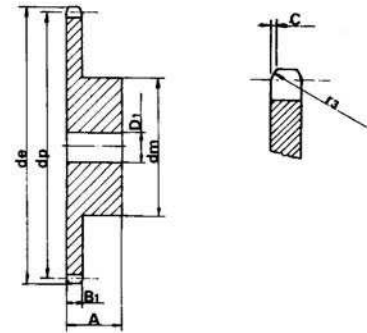

Kettenrad - Pignon mm

r ₃	13
C	1,3
B ₁	4,5

Kette - Chaîne mm

Tl _g - Pas	12,7
Innere Breite - largeur interieur	4,88
Rolle ø - ø Rouleaux	7,75

1/2" x 3/16"

ab z = 90 h = 6 mm
 depuis z = 90 h = 6 mm

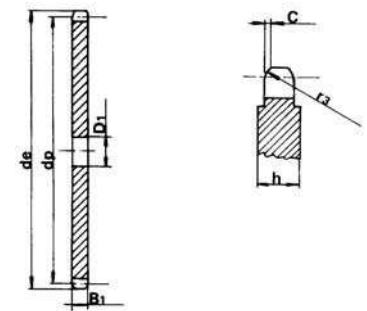

Kettenradscheibe - Roue mm

r ₃	13
C	1,3
B ₁	4,3 ±0,2

Kette - Chaîne mm

Tl _g - Pas	12,7
Innere Breite - largeur interieur	4,88
Rolle ø - ø Rouleaux	7,75

Kettenräder/Kettenradscheiben

Pignons/Roues



Z	d _e	d _p	Simplex			Duplex			Triplex		
			d _m	D ₁	A	d _m	D ₁	A	d _m	D ₁	A
8	57.6	49.78	31	12	30	31	12	45	31	16	65
9	62.0	55.70	37	12	30	37	12	45	37	16	65
10	69.0	61.64	42	12	30	42	12	45	42	16	65
11	75.0	67.61	46	14	35	47	16	50	47	20	70
12	81.5	73.61	52	14	35	53	16	50	53	20	70
13	87.5	79.59	58	14	35	59	16	50	59	20	70
14	93.6	85.61	64	14	35	65	16	50	65	20	70
15	99.8	91.63	70	14	35	71	16	50	71	20	70
16	105.5	97.65	75	16	35	77	20	50	77	20	70
17	111.5	103.67	80	16	35	83	20	50	83	20	70
18	118.0	109.71	80	16	35	89	20	50	89	20	70
19	124.2	115.75	80	16	35	95	20	50	95	20	70
20	129.7	121.78	80	16	35	100	20	50	100	20	70
21	136.0	127.82	90	20	40	100	20	50	100	20	70
22	141.8	133.86	90	20	40	100	20	50	100	20	70
23	149.0	139.9	90	20	40	110	20	50	110	20	70
24	153.9	145.94	90	20	40	110	20	50	110	20	70
25	160.0	152.00	90	20	40	120	20	50	120	20	70
26	165.9	158.04	95	20	40	120	20	50	120	20	70
27	172.3	164.09	95	20	40	120	20	50	120	20	70
28	178.0	170.13	95	20	40	120	20	50	120	20	70
29	184.1	176.19	95	20	40	120	20	50	120	20	70
30	190.5	182.25	95	20	40	120	20	50	120	20	70
31	196.3	188.31	100	20	40	130	20	50	130	25	70
32	203.3	194.35	100	20	40	130	20	50	130	25	70
33	209.3	200.40	100	20	40	130	20	50	130	25	70
34	214.6	206.46	100	20	40	130	20	50	130	25	70
35	221.0	212.52	100	20	40	130	20	50	130	25	70
36	226.8	218.58	100	20	40	130	25	50	130	25	70
37	232.9	224.64	100	20	40	130	25	50	130	25	70
38	239.0	230.69	100	20	40	130	25	50	130	25	70
39	245.1	236.75	100	20	40	130	25	50	130	25	70
40	251.3	242.81	100	20	40	130	25	50	130	25	70

Z	d _e	d _p	S	D ₁	D ₂	T ₃
8	57.6	49.78	12	12	16	16
9	62.0	55.70	12	12	16	16
10	69.0	61.64	12	12	16	16
11	75.0	67.61	14	16	20	20
12	81.5	73.61	14	16	20	20
13	87.5	79.59	14	16	20	20
14	93.6	85.61	14	16	20	20
15	99.8	91.63	14	16	20	20
16	105.5	97.65	14	16	20	20
17	111.5	103.67	14	20	20	20
18	118.0	109.71	14	20	20	20
19	124.2	115.75	14	20	20	20
20	129.7	121.78	14	20	20	20
21	136.0	127.82	16	20	20	20
22	141.8	133.86	16	20	20	20
23	149.0	139.90	16	20	20	20
24	153.9	145.94	16	20	20	20
25	160.0	152.00	16	20	20	20
26	165.9	158.04	16	20	20	20
27	172.3	164.09	16	20	20	20
28	178.0	170.13	16	20	20	20
29	184.1	176.19	16	20	20	20
30	190.5	182.25	16	20	20	20
31	196.3	188.31	20	20	25	25
32	203.3	194.36	20	20	25	25
33	209.2	200.40	20	20	25	25
34	214.6	206.46	20	20	25	25
35	221.0	212.52	20	20	25	25
36	226.8	218.58	20	25	25	25
37	232.9	224.64	20	25	25	25
38	239.0	230.69	20	25	25	25
39	245.1	236.75	20	25	25	25
40	251.3	242.81	20	25	25	25
41	257.3	248.87	25	25	25	25
42	264.5	254.93	25	25	25	25
43	270.5	260.98	25	25	25	25

Z	d _e	d _p	S	D ₁	D ₂	T ₃
44	276.5	267.04	25	25	25	25
45	282.5	273.10	25	25	25	25
46	287.9	279.16	25	25	25	25
47	294.0	285.21	25	25	25	25
48	300.1	291.27	25	25	25	25
49	306.2	297.33	25	25	25	25
50	312.3	303.39	25	25	25	25
51	318.4	309.45	25	25	25	25
52	324.5	315.50	25	25	25	25
53	330.5	321.56	25	25	25	25
54	336.6	327.64	25	25	25	25
55	342.7	333.70	25	25	25	25
56	348.7	339.75	25	25	30	30
57	355.4	345.81	25	25	30	30
58	361.5	351.87	25	25	30	30
59	367.5	357.93	25	25	30	30
60	373.0	363.99	25	25	30	30
62	385.1	376.12	25	30	30	30
64	397.2	388.24	25	30	30	30
66	409.3	400.35	30	30	30	30
68	421.4	412.49	30	30	30	30
70	433.6	424.60	30	30	30	30
72	447.0	436.74	30	30	30	30
75	463.9	454.91	30	30	30	30
76	469.9	460.99	30	30	30	30
78	482.1	473.10	30	30	30	30
80	494.2	485.22	30	30	30	30
85	524.5	515.55	30	30	30	30
90	554.8	545.86	30	30	30	30
95	585.1	576.17	30	30	30	30
100	615.4	606.47	30	30	30	30
110	676.1	667.11	30	30	30	30
114	700.6	691.36	30	30	30	30
120	736.7	727.74	30	30	30	30
125	767.0	758.05	30	30	30	30

3/4" x 7/16"

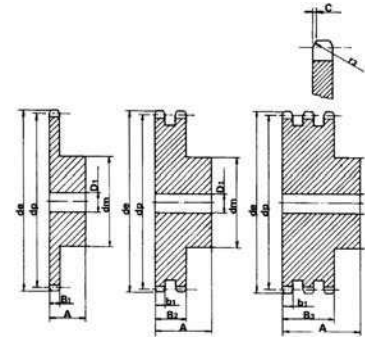

Kettenrad - Pignon mm

r ₃	19
C	2
B ₁	11,1
b ₁	10,8
B ₂	30,3
B ₃	49,8

Kette - Chaîne mm

tlg - Pas	19,05
Innere Breite - largeur interieur	11,68
Rolle ø - ø Rouleaux	12,07

3/4" x 7/16"

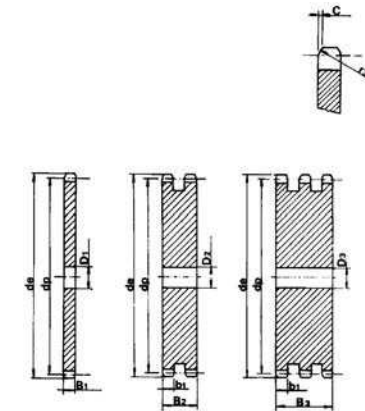

Kettenradscheibe - Roue mm

r ₃	19
C	2
B ₁	11,1
b ₁	10,8
B ₂	30,3
B ₃	49,8

Kette - Chaîne mm

tlg - Pas	19,05
Innere Breite - largeur interieur	11,68
Rolle ø - ø Rouleaux	12,07

Kettenräder/Kettenradscheiben

Pignons/Roues



Z	d_e	d_p	Simplex			Duplex			Triplex		
			d_m	D ₁	A	d_m	D ₁	A	d_m	D ₁	A
8	77.0	66.37	42	16	35	42	16	65	42	20	95
9	85.0	74.27	50	16	35	50	16	65	50	20	95
10	93.0	82.19	55	16	35	56	16	65	56	20	95
11	99.5	90.14	61	16	40	64	20	70	64	25	100
12	109.0	98.14	69	16	40	72	20	70	72	25	100
13	117.0	106.12	78	16	40	80	20	70	80	25	100
14	125.0	114.15	84	16	40	88	20	70	88	25	100
15	133.0	122.17	92	16	40	96	20	70	96	25	100
16	141.0	130.20	100	20	45	104	20	70	104	30	100
17	149.0	138.22	100	20	45	112	20	70	112	30	100
18	157.0	146.28	100	20	45	120	20	70	120	30	100
19	165.2	154.33	100	20	45	128	20	70	128	30	100
20	173.2	162.38	100	20	45	130	20	70	130	30	100
21	181.2	170.43	110	20	50	*130	25	70	*130	30	100
22	189.3	178.48	110	20	50	*130	25	70	*130	30	100
23	197.5	186.53	110	20	50	*130	25	70	*130	30	100
24	205.5	194.59	110	20	50	*130	25	70	*130	30	100
25	213.5	202.66	110	20	50	*130	25	70	*130	30	100
26	221.6	210.72	120	20	50	*130	25	70	*130	30	100
27	229.6	218.79	120	20	50	*130	25	70	*130	30	100
28	237.7	226.85	120	20	50	*130	25	70	*130	30	100
29	245.8	234.92	120	20	50	*130	25	70	*130	30	100
30	254.0	243.00	120	20	50	*130	25	70	*130	30	100
31	262.0	251.08	*120	25	50	*140	25	70	*140	30	100
32	270.0	259.13	*120	25	50	*140	25	70	*140	30	100
33	278.5	267.21	*120	25	50	*140	25	70	*140	30	100
34	287.0	275.28	*120	25	50	*140	25	70	*140	30	100
35	296.2	283.36	*120	25	50	*140	25	70	*140	30	100
36	304.6	291.44	*120	25	50	*140	25	70	*140	30	100
37	312.6	299.51	*120	25	50	*140	25	70	*140	30	100
38	320.7	307.59	*120	25	50	*140	25	70	*140	30	100
39	328.8	315.67	*120	25	50	*140	25	70	*140	30	100
40	336.9	323.75	*120	25	50	*140	25	70	*140	30	100

* angeschweisste Nabe/Moyeux soudée

Z	d_e	d_p	S	D	T
			D ₁	D ₂	D ₃
8	77.0	66.37	14	16	20
9	85.0	74.27	14	16	20
10	93.0	82.19	15	16	20
11	99.5	90.14	15	20	25
12	109.0	98.14	15	20	25
13	117.0	106.12	15	20	25
14	125.0	114.15	15	20	25
15	133.0	122.17	15	20	25
16	141.0	130.20	19	20	30
17	149.0	138.22	19	20	30
18	157.0	146.28	19	20	30
19	165.2	154.33	19	20	30
20	173.0	162.38	19	20	30
21	181.2	170.43	20	25	30
22	189.3	178.48	20	25	30
23	197.5	186.53	20	25	30
24	205.5	194.59	20	25	30
25	213.5	202.66	20	25	30
26	221.6	210.72	20	25	30
27	229.6	218.79	20	25	30
28	237.7	226.85	20	25	30
29	245.8	234.92	20	25	30
30	254.0	243.00	20	25	30
31	262.0	251.08	25	25	30
32	270.0	259.13	25	25	30
33	278.5	267.21	25	25	30
34	287.0	275.28	25	25	30
35	296.2	283.36	25	25	30
36	304.6	291.44	25	25	30
37	312.6	299.51	25	25	30
38	320.7	307.59	25	25	30
39	328.8	315.67	25	25	30
40	336.9	323.75	25	25	30
41	345.0	331.82	25	25	30
42	353.0	339.90	25	25	30
43	361.1	347.98	25	25	30

Z	d_e	d_p	S	D	T
			D ₁	D ₂	D ₃
44	369.1	356.06	25	25	30
45	377.1	364.13	25	25	30
46	385.2	372.21	25	30	30
47	393.2	380.29	25	30	30
48	401.3	388.36	25	30	30
49	409.3	396.44	25	30	30
50	417.4	404.52	25	30	30
51	425.5	412.60	30	30	40
52	433.6	420.67	30	30	40
53	441.7	428.75	30	30	40
54	449.8	436.85	30	30	40
55	457.9	444.93	30	30	40
56	466.0	453.01	30	30	40
57	474.0	461.07	30	30	40
58	482.1	469.16	30	30	40
59	490.2	477.24	30	30	40
60	498.3	485.32	30	30	40
62	514.5	501.50	30	30	40
64	530.7	517.65	30	30	40
65	538.8	525.73	30	30	40
66	546.8	533.80	30	30	40
68	562.9	549.98	30	30	40
70	579.2	566.14	30	30	40
72	595.4	582.32	30	30	40
75	619.7	606.55	30	30	40
76	627.0	614.65	30	30	40
78	643.3	630.80	30	30	40
80	660.0	646.96	30	30	40
85	699.9	687.40	30	30	40
90	740.3	727.81	30	30	40
95	781.1	768.22	30	30	40
100	821.1	808.63	30	30	40
110	902.0	889.48	30	30	40
114	934.3	921.81	30	40	40
120	982.8	970.33	30	40	40
125	1023.2	1010.73	30	40	40

1" x 17,02 mm

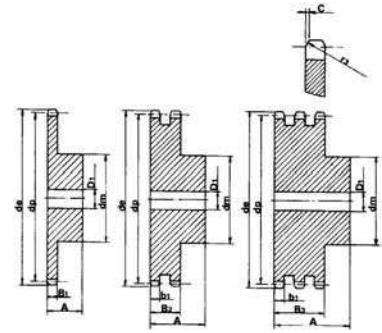

Kettenrad - Pignon

	mm
r ₃	26
C	2,5
B ₁	16,2
b ₁	15,8
B ₂	47,7
B ₃	79,6

Kette - Chaîne

	mm
Tl _g - Pas	25,4
Innere Breite - largeur interieur	17,02
Rolle ø - ø Rouleaux	15,88

1" x 17,02 mm

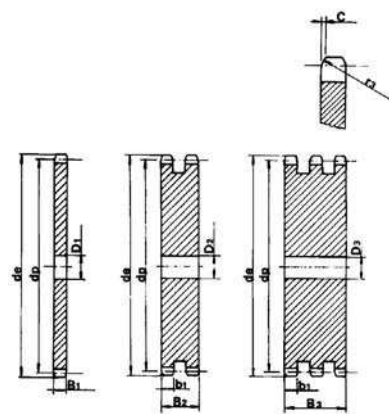

Kettenradscheibe - Roue

	mm
r ₃	26
C	2,5
B ₁	16,2
b ₁	15,8
B ₂	47,7
B ₃	79,6

Kette - Chaîne

	mm
Tl _g - Pas	25,4
Innere Breite - largeur interieur	17,02
Rolle ø - ø Rouleaux	15,88

Kettenräder/Kettenradscheiben

Pignons/Roues



Z	d _e	d _p	Simplex			Duplex			Triplex		
			d _m	D ₁	A	d _m	D ₁	A	d _m	D ₁	A
8	98.1	82.96	53	20	40	53	20	75	53	20	110
9	108.0	92.84	63	20	40	63	20	75	63	20	110
10	117.9	102.74	70	20	40	70	20	75	70	20	110
11	127.8	112.68	77	20	45	80	20	80	80	20	115
12	137.8	122.68	88	20	45	90	20	80	90	20	115
13	147.8	132.65	98	20	45	100	20	80	100	20	115
14	157.8	142.68	108	20	45	110	20	80	110	20	115
15	167.9	152.72	118	20	45	120	20	80	120	20	115
16	177.9	162.75	120	25	50	120	25	80	120	25	115
17	187.9	172.78	120	25	50	120	25	80	120	25	115
18	198.0	182.85	120	25	50	*120	25	80	*120	25	115
19	208.1	192.91	120	25	50	*120	25	80	*120	25	115
20	218.1	202.98	120	25	50	*120	25	80	*120	25	115
21	228.2	213.04	140	25	55	*140	25	80	*140	25	115
22	238.3	223.11	140	25	55	*140	25	80	*140	25	115
23	248.3	233.17	140	25	55	*140	25	80	*140	25	115
24	258.4	243.23	140	25	55	*140	25	80	*140	25	115
25	268.5	253.33	140	25	55	*140	25	80	*140	25	115
26	278.6	263.40	*150	25	55	*150	25	80	*150	25	115
27	288.6	273.49	*150	25	55	*150	25	80	*150	25	115
28	298.7	283.56	*150	25	55	*150	25	80	*150	25	115
29	308.8	293.65	*150	25	55	*150	25	80	*150	25	115
30	318.9	303.75	*150	25	55	*150	25	80	*150	25	115
31	329.0	313.85	*160	25	55	*150	25	80	*150	30	115
32	339.1	323.91	*160	25	55	*150	25	80	*150	30	115
33	349.2	334.01	*160	25	55	*150	25	80	*150	30	115
34	359.3	344.10	*160	25	55	*150	25	80	*150	30	115
35	369.4	354.20	*160	25	55	*150	25	80	*150	30	115
36	379.5	364.30	*160	25	55	*150	30	80	*150	30	115
37	389.5	374.39	*160	25	55	*150	30	80	*150	30	115
38	399.6	384.49	*160	25	55	*150	30	80	*150	30	115
39	409.7	394.59	*160	25	55	*150	30	80	*150	30	115
40	419.8	404.69	*160	25	55	*150	30	80	*150	30	115

* angeschweisste Nabe/Moyeux soudée

Z	d _e	d _p	S	D	T
			D ₁	D ₂	D ₃
8	98.1	82.96	16	20	20
9	108.0	92.84	16	20	20
10	117.9	102.74	16	20	20
11	127.8	112.68	16	20	20
12	137.8	122.68	20	20	20
13	147.8	132.65	20	20	20
14	157.8	142.68	20	20	20
15	167.9	152.72	20	20	20
16	177.9	162.75	25	25	25
17	187.9	172.78	25	25	25
18	198.0	182.85	25	25	25
19	208.1	192.91	25	25	25
20	218.1	202.98	25	25	25
21	228.2	213.04	25	25	25
22	238.3	223.11	25	25	25
23	248.3	233.17	25	25	25
24	258.4	243.23	25	25	25
25	268.5	253.33	25	25	25
26	278.6	263.40	25	25	25
27	288.6	273.40	25	25	25
28	298.7	283.56	25	25	25
29	308.8	293.65	25	25	25
30	318.9	303.75	25	25	25
31	329.0	313.85	25	25	30
32	339.1	323.91	25	25	30
33	349.2	334.01	25	25	30
34	359.3	344.10	25	25	30
35	369.4	354.20	25	25	30
36	379.5	364.30	25	30	30
37	389.5	374.39	25	30	30
38	399.6	384.49	25	30	30
39	409.7	394.59	25	30	30
40	419.8	404.68	25	30	30
41	429.9	414.78	30		
42	440.0	424.88	30	30	40

Z	d _e	d _p	S	D	T
			D ₁	D ₂	D ₃
43	450.1	434.97	30		
44	460.2	445.07	30		
45	470.3	455.17	30	30	40
46	480.4	465.26	30	30	40
47	490.5	475.36	30		
48	500.6	485.46	30	30	40
49	510.7	495.55	30		
50	520.8	505.65	30	30	40
51	530.9	515.75	30		
52	541.0	525.84	30	30	40
53	551.1	535.94	30		
54	561.2	546.07	30		
55	571.3	556.16	30	30	40
56	581.4	566.26	30		
57	591.5	576.36	30	30	40
58	601.6	586.45	30		
59	611.7	596.55	30		
60	621.8	606.65	30	30	40
62	642.0	626.87	30		
64	662.2	647.06	30		
65	672.3	657.16	30	30	40
66	682.4	667.26	30		
68	702.6	687.48	30		
70	722.8	707.67	30	30	40
72	743.1	727.90	30		
75	773.3	758.19	30		
76	783.5	768.32	30	30	40
80	823.9	808.72	30	30	40
85	874.4	859.25	30		
90	924.9	909.76	30		
95	975.4	960.28	30	30	40
100	1026.0	1010.79	30		
114	1167.4	1152.26	30	40	40

1 1/4" x 3/4"

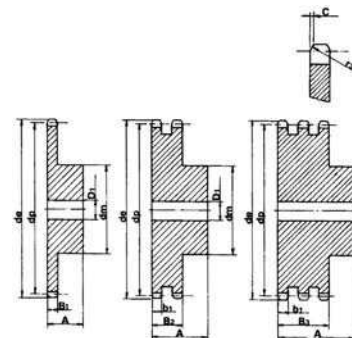

Kettenrad - Pignon	mm
r ₃	32
C	3,5
B ₁	18,5
b ₁	18,2
B ₂	54,6
B ₃	91

Kette - Chaîne	mm
Tlg - Pas	31,75
Innere Breite - largeur interieur	19,56
Rolle ø - ø Rouleaux	19,05

1 1/4" x 3/4"

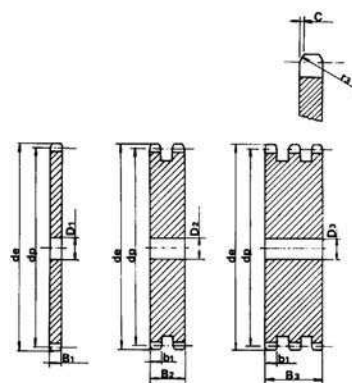

Kettenradscheibe - Roue	mm
r ₃	32
C	3,5
B ₁	18,5
b ₁	18,2
B ₂	54,6
B ₃	91

Kette - Chaîne	mm
Tlg - Pas	31,75
Innere Breite - largeur interieur	19,56
Rolle ø - ø Rouleaux	19,05

Kettenräder/Kettenradscheiben

Pignons/Roues

Z	d _e	d _p	Simplex			Duplex			Triplex		
			d _m	D ₁	A	d _m	D ₁	A	d _m	D ₁	A
8	115.0	99.55	58	20	45	58	25	95	58	25	140
9	126.4	111.40	70	20	45	70	25	95	70	25	140
10	138.0	123.29	80	20	45	80	25	95	80	25	140
11	150.0	135.21	90	25	50	90	25	100	90	25	150
12	162.0	147.22	102	25	50	102	25	100	102	25	150
13	174.2	159.18	114	25	50	114	25	100	114	25	150
14	186.2	171.22	128	25	50	128	25	100	128	25	150
15	198.2	183.26	140	25	50	140	25	100	140	25	150
16	210.3	195.30	*140	25	55	*140	25	100	*140	25	150
17	222.3	207.34	*140	25	55	*150	25	100	*150	25	150
18	234.3	219.42	*140	25	55	*160	25	100	*160	25	150
19	246.5	231.49	*140	25	55	*160	25	100	*160	25	150
20	258.6	243.57	*140	25	55	*160	25	100	*160	25	150
21	270.6	255.65	*150	25	60	*160	25	100	*160	30	150
22	282.7	267.73	*150	25	60	*160	25	100	*160	30	150
23	294.8	279.80	*150	25	60	*160	25	100	*160	30	150
24	306.8	291.88	*150	25	60	*160	25	100	*160	30	150
25	319.0	304.00	*150	25	60	*160	25	100	*160	30	150
26	331.0	316.08	*160	30	60	*160	30	100	*160	30	150
27	343.2	328.19	*160	30	60	*160	30	100	*160	30	150
28	355.2	340.27	*160	30	60	*160	30	100	*160	30	150
29	367.3	352.38	*160	30	60	*160	30	100	*160	30	150
30	379.5	364.50	*160	30	60	*160	30	100	*160	40	150
31	391.6	376.62	*160	30	60	*170	30	100			
32	403.7	388.69	*160	30	60	*170	30	100	*170	40	150
33	415.8	400.81	*160	30	60	*170	30	100	*170	40	150
34	427.8	412.93	*160	30	60	*170	30	100	*170	40	150
35	440.0	425.04	*160	30	60	*170	30	100	*170	40	150
36	452.0	437.16	*160	30	60	*170	30	100	*170	40	150
37	464.2	449.27	*160	30	60	*170	30	100			
38	476.2	461.39	*160	30	60	*170	30	100	*170	40	150
39	488.5	473.50	*160	30	60	*170	30	100			
40	500.6	485.62	*160	30	60	*170	30	100	*170	40	150

* angeschweisste Nabe/Moyeux soudée

Z	d _e	d _p	S	D		T
				D ₁	D ₂	
8	115.0	99.55	20	25	25	25
9	126.4	111.40	20	25	25	25
10	138.0	123.29	20	25	25	25
11	150.0	135.21	20	25	25	25
12	162.0	147.22	20	25	25	25
13	174.2	159.18	20	25	25	25
14	186.2	171.22	20	25	25	25
15	198.2	183.26	20	25	25	25
16	210.3	195.30	25	25	25	25
17	222.3	207.34	25	25	25	25
18	234.3	219.42	25	25	25	25
19	246.5	231.49	25	25	25	25
20	258.6	243.57	25	25	25	25
21	270.6	255.65	25	25	30	30
22	282.7	267.73	25	25	30	30
23	294.8	279.80	25	25	30	30
24	306.8	291.88	25	25	30	30
25	319.0	304.00	25	25	30	30
26	331.0	316.08	30	30	30	30
27	343.2	328.19	30	30	30	30
28	355.2	340.27	30	30	30	30
29	367.3	352.38	30	30	30	30
30	379.5	364.50	30	30	40	40
31	391.6	376.62	30	30		
32	403.7	388.69	30	30	40	40
33	415.8	400.81	30	30	40	40
34	427.8	412.93	30	30	40	40
35	440.0	425.04	30	30	40	40
36	452.0	437.16	30	30	40	40
37	464.2	449.27	30	30		
38	476.2	461.39	30	30	40	40
39	488.5	473.50	30	30		
40	500.6	485.62	30	30	40	40
41	512.6	497.74	30			
42	524.7	509.85	30	40	40	40

Z	d _e	d _p	S	D		T
				D ₁	D ₂	
43	536.8	521.97	30			
44	549.0	534.08	30			
45	561.2	546.20	30	40	40	
46	573.3	558.32	30	40	40	
47	585.4	570.43	30			
48	597.4	582.55	30	40	40	
49	609.5	594.66	30			
50	621.7	606.78	30	40	40	
51	633.8	618.89	30			
52	646.0	631.01	30			
53	658.0	643.13	30			
54	670.2	655.28	30			
55	682.3	667.40	30	40	40	
56	694.4	679.51	30			
57	706.5	691.63	30	40	40	
58	718.6	703.74	30			
59	730.7	715.86	30			
60	742.8	727.97	30	40	40	
62	767.2	752.24	40			
64	791.3	776.48	40			
65	803.4	788.59	40	40	40	
66	815.6	800.71	40			
68	839.8	824.98	40			
70	864.2	849.21	40			
72	888.4	873.48	40			
75	924.8	909.83	40			
76	936.9	921.98	40	40	40	
80	985.4	970.44	40			
85	1046.0	1031.10	40			
95	1167.3	1152.33	40			

1 1/2" x 1"

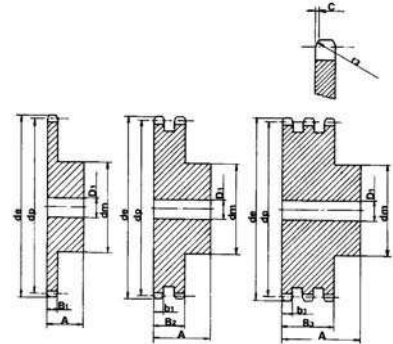

Kettenrad - Pignon	mm
r ₃	38
C	4
B ₁	242,1
b ₁	23,6
B ₂	72
B ₃	120,3

Kette - Chaîne	mm
tlg - Pas	38,1
Innere Breite - largeur interieur	25,4
Rolle ø - ø Rouleaux	25,4

1 1/2" x 1"

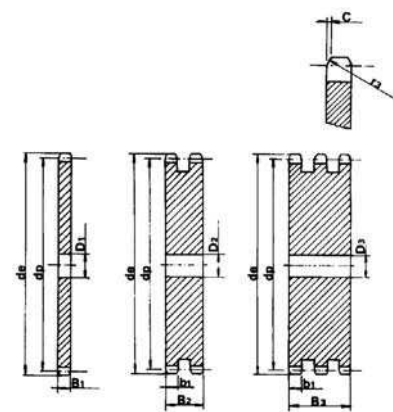

Kettenradscheibe - Roue	mm
r ₃	38
C	4
B ₁	242,1
b ₁	23,6
B ₂	72
B ₃	120,3

Kette - Chaîne	mm
tlg - Pas	38,1
Innere Breite - largeur interieur	25,4
Rolle ø - ø Rouleaux	25,4

Kettenräder/Kettenradscheiben

Pignons/Roues



Z	d _e	d _p	Simplex			Duplex			Triplex		
			d _m	D ₁	A	d _m	D ₁	A	d _m	D ₁	A
8	132.0	116.15	74	25	70	74	25	120	74	30	180
9	148.4	129.96	88	25	70	88	25	120	88	30	180
10	162.3	143.85	100	25	70	100	25	120	100	30	180
11	176.3	157.77	112	25	70	112	25	120	112	30	180
12	189.5	171.74	125	25	70	125	25	120	125	30	180
13	204.2	185.75	*130	25	70	*130	25	120	*130	30	180
14	218.2	199.76	*130	25	70	*130	25	120	*130	30	180
15	232.3	213.79	*145	25	70	*145	25	120	*145	30	180
16	246.3	227.84	*160	30	75	*160	30	120	*160	30	180
17	260.0	241.91	*160	30	75	*160	30	120	*160	30	180
18	274.0	255.98	*160	30	75	*160	30	120	*160	30	180
19	289.0	270.06	*160	30	75	*180	30	120	*180	30	180
20	303.0	284.15	*160	30	75	*180	30	120	*180	30	180
21	317.0	298.24	*170	30	75	*180	30	120	*180	30	180
22	331.0	312.34	*170	30	75	*180	30	120	*180	30	180
23	345.0	326.44	*170	30	75	*180	30	120	*180	30	180
24	359.0	340.55	*170	30	75	*180	30	120	*180	30	180
25	373.0	354.66	*170	30	75	*180	30	120	*180	40	180
26	387.0	368.77	*170	30	75	*180	30	120	*180	40	180
27	401.4	382.88	*170	30	75	*180	30	120	*180	40	180
28	416.0	397.00	*170	30	75	*180	30	120	*180	40	180
29	430.0	411.12	*170	30	75	*180	30	120			
30	444.0	425.24	*170	30	75	*180	30	120	*180	40	180
31	458.0	439.37	*180	30	75						
32	472.0	453.49	*180	30	75						
33	486.0	467.62	*180	30	75						
34	500.0	481.75	*180	30	75						
35	514.0	495.88	*180	30	75	*200	30	120	*200	40	180
36	529.0	510.01	*180	30	75						
37	543.0	524.14	*180	30	75						
38	557.0	538.27	*180	30	75	*200	30	120	*200	40	180
39	571.0	552.40	*180	30	75						
40	585.0	566.54	*180	30	75	*200	30	120	*200	40	180

* angeschweisste Nabe/Moyeux soudée

Z	d _e	d _p	S	D	T
			D ₁	D ₂	D ₃
8	132.0	116.15	25	25	25
9	148.4	129.96	25	25	25
10	162.3	143.85	25	25	25
11	176.3	157.77	25	25	30
12	189.5	171.74	25	25	30
13	204.2	185.75	25	25	30
14	218.2	199.76	25	25	30
15	232.3	213.79	25	25	30
16	246.3	227.84	30	30	30
17	260.0	241.91	30	30	30
18	274.0	255.98	30	30	30
19	289.0	270.06	30	30	30
20	303.0	284.15	30	30	30
21	317.0	298.24	30	30	30
22	331.0	312.34	30	30	30
23	345.0	326.44	30	30	30
24	359.0	340.55	30	30	30
25	373.0	354.66	30	30	40
26	387.0	368.77	30	30	40
27	401.4	382.88	30	30	40
28	416.0	397.00	30	30	40
29	430.0	411.12	30	30	
30	444.0	425.24	30	30	40
31	458.0	439.37	30		
32	472.0	453.49	30		
33	486.0	467.62	30		
34	500.0	481.75	30		
35	514.0	495.88	30	30	40
36	529.0	510.01	30		
37	543.0	524.14	30		
38	557.0	538.27	30	30	40
39	571.0	552.40	30		
40	585.0	566.54	30	30	40
45	656.0	637.22	30	30	40
50	726.0	707.91	30	30	40

Z	d _e	d _p	S	D	T
			D ₁	D ₂	D ₃
57	825.0	806.90	40	40	40
60	869.0	849.32	40	40	40
76	1095.0	1075.62	40	40	40

1 3/4" x 1 1/4"

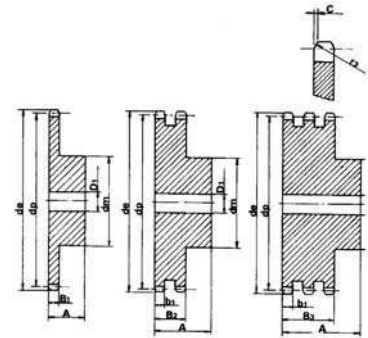

Kettenrad - Pignon	mm
r ₃	44
C	5
B ₁	29,4
b ₁	28,8
B ₂	88,4
B ₃	148

Kette - Chaîne	mm
tlg - Pas	44,45
Innere Breite - largeur interieur	30,99
Rolle ø - ø Rouleaux	27,94

1 3/4" x 1 1/4"

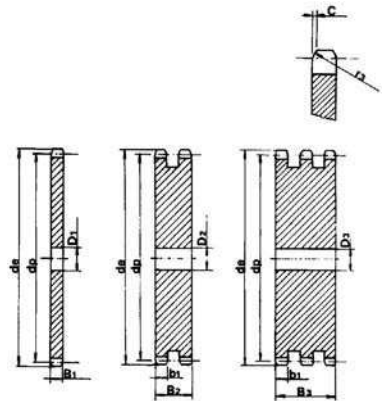

Kettenradscheibe - Roue	mm
r ₃	44
C	5
B ₁	29,4
b ₁	28,8
B ₂	88,4
B ₃	148

Kette - Chaîne	mm
tlg - Pas	44,45
Innere Breite - largeur interieur	30,99
Rolle ø - ø Rouleaux	27,94

Kettenräder/Kettenradscheiben

Pignons/Roues

Z	d _e	d _p	Simplex			Duplex			Triplex		
			d _m	D ₁	A	d _m	D ₁	A	d _m	D ₁	A
8	153.2	132.69	82	25	80	82	30	120	82	30	180
9	169.0	148.54	88	25	80	88	30	120	88	30	180
10	185.0	164.44	104	25	80	104	30	120	104	30	180
11	200.8	180.34	120	30	80	120	30	120	120	30	180
12	216.8	196.29	*133	30	80	*133	30	120	*133	30	180
13	232.8	212.29	*145	30	80	*145	30	120	*145	30	180
14	248.8	228.29	*160	30	80	*160	30	120	*160	30	180
15	264.8	244.30	*160	30	80	*160	30	120	*160	30	180
16	280.9	260.40	*160	30	90	*160	30	120	*160	30	180
17	296.9	276.40	*170	30	90	*180	30	120	*180	30	180
18	313.0	292.55	*170	30	90	*180	30	120	*180	30	180
19	329.1	308.66	*170	30	90	*200	30	120	*200	30	180
20	345.2	324.71	*180	30	90	*200	30	120	*200	30	180
21	361.3	340.82	*180	30	90	*200	30	120	*200	40	180
22	377.5	356.98	*180	30	90	*200	30	120	*200	40	180
23	393.6	373.08	*180	30	90	*200	30	120	*200	40	180
24	409.7	389.18	*180	30	90	*200	30	120	*200	40	180
25	425.8	405.33	*180	30	90	*200	30	120	*200	40	180
26	441.9	421.44	*180	30	90	*200	30	120	*200	40	180
27	458.1	437.59	*180	30	90	*200	30	120	*200	40	180
28	474.2	453.69	*180	30	90	*200	30	120	*200	40	180
29	490.4	469.90	*180	30	90						
30	506.5	486.00	*180	30	90	*200	30	120	*200	40	180
32	538.8	518.28	*180	30	90						
35	589.5	566.72	*180	30	90						
38	635.5	615.14	*180	30	90						
40	670.3	647.49	*180	30	90						

* angeschweisste Nabe/Moyeux soudée

Z	d _e	d _p	S	D	T
8	153.2	132.69	25	25	25
9	169.0	148.54	25	25	25
10	185.0	164.44	25	25	25
11	200.8	180.34	30	30	30
12	216.8	196.29	30	30	30
13	232.8	212.29	30	30	30
14	248.8	228.29	30	30	30
15	264.8	244.30	30	30	30
16	280.9	260.40	30	30	30
17	296.9	276.40	30	30	30
18	313.0	292.55	30	30	30
19	329.1	308.66	30	30	30
20	345.2	324.71	30	30	30
21	361.3	340.82	30	30	40
22	377.5	356.98	30	30	40
23	393.6	373.08	30	30	40
24	409.7	389.18	30	30	40
25	425.8	405.33	30	30	40
26	441.9	421.44	30	30	40
27	458.1	437.59	30	30	40
28	474.2	453.69	30	30	40
29	490.4	469.90	30		
30	506.5	486.00	30	30	40
32	538.8	518.26	30		
35	589.5	566.72	30	30	40
38	635.5	615.14	30	30	40
40	670.3	647.49	40	40	40
45	751.0	728.26	40	40	40
50	831.8	809.04	40	40	40
57	945.0	922.17	40	40	40
60	993.4	970.63	40	40	40

Z	d _e	d _p	S	D	T
76	1252.0	1229.28	40	40	40

2" x 1 1/4"

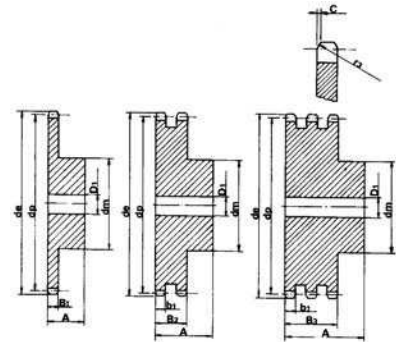

Kettenrad - Pignon

	mm
r ₃	51
C	5
B ₁	29,4
b ₁	28,8
B ₂	87,4
B ₃	146

Kette - Chaîne

	mm
tlg - Pas	50,8
Innere Breite - largeur interieur	30,99
Rolle ø - ø Rouleaux	29,21

2" x 1 1/4"

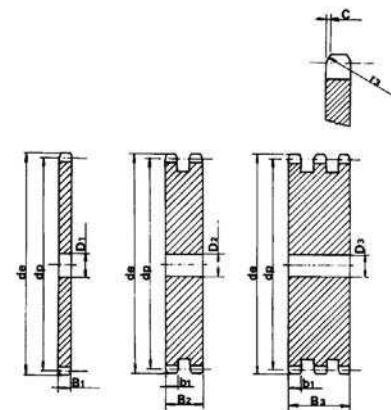

Kettenradscheibe - Roue

	mm
r ₃	51
C	5
B ₁	29,4
b ₁	28,8
B ₂	87,4
B ₃	146

Kette - Chaîne

	mm
tlg - Pas	50,8
Innere Breite - largeur interieur	30,99
Rolle ø - ø Rouleaux	29,21

Kettenräder Pignons

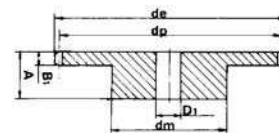

Kettenräder Rostfrei – Pignons Inox

PITCH	Z	12	13	15	16	17	18	19	20	21	23	25	30
3/8" × 7/32"	de	-	43.00	49.30	52.30	55.30	58.30	61.30	64.30	68.00	73.50	80.00	94.70
	dp	-	39.79	45.81	48.82	51.83	54.85	57.87	60.89	63.91	69.65	76.00	91.12
	dm	-	28.00	34.00	37.00	40.00	43.00	45.00	46.00	48.00	52.00	57.00	60.00
	D ₁	-	10.00	10.00	10.00	10.00	10.00	10.00	10.00	10.00	12.00	12.00	12.00
	A	-	25.00	25.00	28.00	28.00	28.00	28.00	28.00	28.00	28.00	28.00	28.00
1/2" × 5/16"	de	53.00	57.90	65.90	69.90	74.00	78.00	82.00	86.00	90.01	98.01	106.2	126.30
	dp	49.07	53.60	61.09	65.10	69.11	73.14	77.16	81.19	85.22	93.27	101.33	121.50
	dm	33.00	37.00	45.00	50.00	52.00	56.00	60.00	64.00	68.00	70.00	70.00	80.00
	D ₁	10.00	10.00	10.00	12.00	12.00	12.00	12.00	12.00	14.00	14.00	14.00	16.00
	A	28.00	28.00	28.00	28.00	28.00	28.00	28.00	28.00	28.00	28.00	28.00	28.00
5/8" × 3/8"	de	-	73.00	83.00	88.00	93.00	98.30	103.30	108.40	113.40	123.40	134.00	158.80
	dp	-	66.32	76.36	81.37	86.39	91.42	96.45	101.49	106.52	116.58	126.66	151.87
	dm	-	47.00	57.00	60.00	60.00	70.00	75.00	75.00	80.00	80.00	80.00	90.00
	D ₁	-	12.00	12.00	12.00	12.00	12.00	14.00	14.00	16.00	16.00	16.00	20.00
	A	-	30.00	30.00	30.00	30.00	30.00	30.00	30.00	30.00	30.00	30.00	35.00
3/4" × 7/16"	de	-	87.50	99.80	105.50	111.50	118.00	124.20	129.70	136.00	149.00	160.00	-
	dp	-	79.59	91.63	97.65	103.67	109.71	115.75	121.78	127.82	139.90	152.00	-
	dm	-	58.00	70.00	75.00	80.00	80.00	80.00	80.00	90.00	90.00	90.00	-
	D ₁	-	16.00	16.00	16.00	16.00	16.00	16.00	16.00	20.00	20.00	20.00	-
	A	-	35.00	35.00	35.00	35.00	35.00	35.00	35.00	40.00	40.00	40.00	-
1" × 17.02	de	-	117.00	133.00	141.00	149.00	157.00	165.20	163.00	181.20	-	-	-
	dp	-	106.12	122.17	130.20	138.22	146.28	154.33	162.38	170.43	-	-	-
	dm	-	78.00	92.00	100.00	100.00	100.00	100.00	100.00	110.00	-	-	-
	D ₁	-	16.00	16.00	19.00	20.00	20.00	20.00	20.00	20.00	-	-	-
	A	-	40.00	40.00	45.00	45.00	45.00	45.00	45.00	50.00	-	-	-

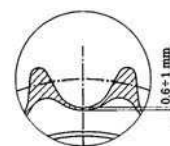

Kettenräder mit gehärteten Zähnen – Pignons avec dentures trempées

PITCH	Z	13	14	15	16	17	18	19	20	21	22	23	25	27
3/8" × 7/32"	de	43.00	-	49.30	52.30	55.30	58.30	61.30	64.30	68.00	73.50	80.00	86.00	94.70
	dp	39.79	-	45.81	48.82	51.83	54.85	57.87	60.89	63.91	69.95	76.00	82.05	91.12
	dm	28.00	-	34.00	37.00	40.00	43.00	45.00	46.00	48.00	52.00	57.00	60.00	60.00
	D ₁	10.00	-	10.00	10.00	10.00	10.00	10.00	10.00	10.00	12.00	12.00	12.00	12.00
	A	25.00	-	25.00	28.00	28.00	28.00	28.00	28.00	28.00	28.00	28.00	28.00	28.00
1/2" × 5/16"	de	57.40	61.80	65.90	69.90	74.00	78.00	82.00	86.00	90.10	98.10	106.20	114.00	126.30
	dp	53.60	57.07	61.09	65.10	69.11	73.14	77.16	81.19	85.22	93.27	101.33	109.40	121.50
	dm	37.00	41.00	45.00	50.00	52.00	56.00	60.00	64.00	68.00	70.00	70.00	70.00	80.00
	D ₁	10.00	10.00	10.00	12.00	12.00	12.00	12.00	12.00	14.00	14.00	14.00	16.00	16.00
	A	28.00	28.00	28.00	28.00	28.00	28.00	28.00	28.00	28.00	28.00	28.00	30.00	30.00
5/8" × 3/8"	de	73.00	76.20	83.00	88.00	93.00	98.30	103.30	108.40	113.40	123.40	134.00	143.5	158.70
	dp	66.32	71.34	76.36	81.37	86.39	91.42	96.45	101.49	106.52	116.58	126.66	136.74	151.87
	dm	47.00	52.00	57.00	60.00	60.00	70.00	75.00	75.00	80.00	80.00	80.00	80	90.00
	D ₁	12.00	12.00	12.00	12.00	12.00	12.00	14.00	14.00	16.00	16.00	16.00	16	20.00
	A	30.00	30.00	30.00	30.00	30.00	30.00	30.00	30.00	30.00	30.00	30.00	30	35.00
3/4" × 7/16"	de	87.50	93.80	99.80	105.50	111.50	118.00	124.20	129.70	136.00	149.00	160.00	171.6	189.80
	dp	79.59	85.61	91.63	97.65	103.67	109.71	115.75	121.78	127.82	139.90	152.00	164.09	182.25
	dm	58.00	64.00	70.00	75.00	80.00	80.00	80.00	80.00	90.00	90.00	90.00	90	95.00
	D ₁	14.00	16.00	16.00	16.00	16.00	16.00	16.00	16.00	20.00	20.00	20.00	20	20.00
	A	35.00	35.00	35.00	35.00	35.00	35.00	35.00	35.00	40.00	40.00	40.00	40	40.00
1" × 17.02	de	117.00	125.70	133.00	141.00	149.00	157.00	165.20	173.00	181.20	197.6	213.7	-	-
	dp	106.12	114.15	122.17	130.20	138.22	146.28	154.33	162.38	170.43	186.54	202.66	-	-
	dm	78.00	84.00	92.00	100.00	100.00	100.00	100.00	100.00	110.00	110	110	-	-
	D ₁	16.00	16.00	16.00	19.00	20.00	20.00	20.00	20.00	20.00	20	20	-	-
	A	40.00	40.00	40.00	45.00	45.00	45.00	45.00	45.00	50.00	50	50	-	-

Kettenräder aus Guss, Simplex, Duplex, Triplex

Pignons en fonte, simples, doubles, triples

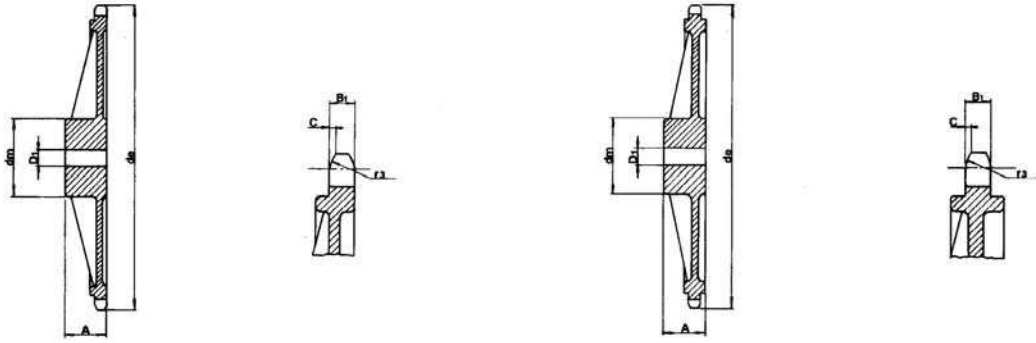

3/8" x 7/32"

Z	d _e	d _p	Simplex			Duplex			Triplex		
			d _m	D ₁	A	d _m	D ₁	A	d _m	D ₁	A
38	119.5	115.35	70	19	32	80	19	40	90	23	56
45	140.7	136.55	70	19	32	80	19	40	90	23	56
57	176.9	172.91	70	19	32	80	19	40	90	23	56
76	234.9	230.49	70	19	32	80	19	40	100	23	56
95	292.5	288.08	80	19	40	90	19	45	100	23	56
114	349.6	345.68	80	19	40	90	19	45	100	23	56
150	459.2	454.82	90	23	45	100	23	50	125	23	60

1/2" x 5/16"

Z	d _e	d _p	Simplex			Duplex			Triplex		
			d _m	D ₁	A	d _m	D ₁	A	d _m	D ₁	A
38	158.6	153.80	70	19	40	90	23	50	100	23	60
45	188	182.07	70	19	40	90	23	50	100	23	60
57	236.4	230.54	70	19	40	90	23	50	100	23	60
76	313.3	307.33	80	23	40	100	23	56	100	23	60
95	390.1	384.11	80	23	45	100	23	56	120	23	67
114	466.9	460.90	90	23	45	100	23	63	120	23	67

5/8" x 3/8"

Z	d _e	d _p	Simplex			Duplex			Triplex		
			d _m	D ₁	A	d _m	D ₁	A	d _m	D ₁	A
38	199.2	192.24	80	19	40	100	29	50	100	31	60
45	235	227.58	80	19	40	100	29	50	100	31	60
57	296	288.18	90	23	45	100	29	56	100	31	63
76	392.1	384.16	90	23	50	100	29	63	110	34	67
95	488.5	480.14	100	23	56	110	29	63	125	34	70
114	584.1	576.13	100	23	56	125	29	70	125	34	80

3/4" x 7/16"

Z	d _e	d _p	Simplex			Duplex			Triplex		
			d _m	D ₁	A	d _m	D ₁	A	d _m	D ₁	A
38	239	230.69	100	23	56	110	29	63	140	31	70
45	282.5	273.1	100	23	56	110	29	63	140	31	70
57	354	345.81	100	29	56	120	29	63	140	39	70
76	469.9	460.99	100	29	56	135	29	63	160	39	75
95	585.1	576.17	100	29	65	135	29	70	170	39	82
114	700.6	691.36	100	29	65	135	44	70	170	49	82

Kettenräder aus Guss, Simplex, Duplex, Triplex

Pignons en fonte, simples, doubles, triples

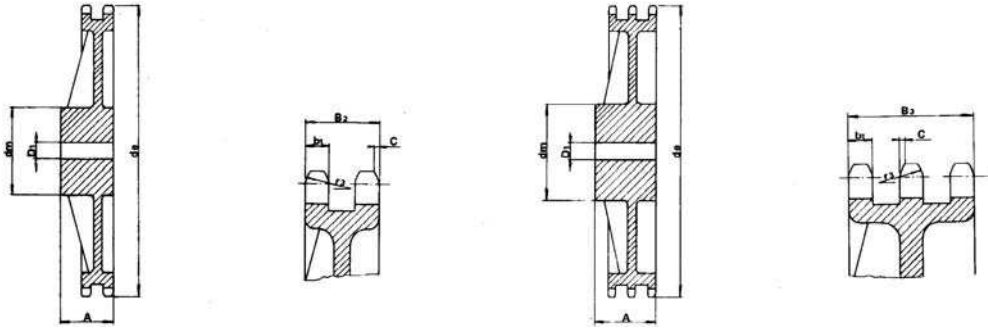

1" x 17.02 mm

Z	d _e	d _p	Simplex			Duplex			Triplex		
			d _m	D ₁	A	d _m	D ₁	A	d _m	D ₁	A
30	254.0	243.00	110	29	65	125	39	75	145	39	90
38	320.0	307.59	110	29	65	140	39	75	160	44	100
45	377.0	364.13	125	29	70	148	39	75	160	44	100
57	474.0	461.08	125	34	70	160	39	90	165	44	100
76	627.0	614.65	140	34	80	175	39	95	200	44	110
95	781.0	768.22	140	39	80	175	44	95	200	49	110
114	933.0	921.81	150	39	80	175	44	95	200	49	115

1 1/4" x 3/4"

Z	d _e	d _p	Simplex			Duplex			Triplex		
			d _m	D ₁	A	d _m	D ₁	A	d _m	D ₁	A
30	318.9	303.75	115	34	70	130	39	80			
38	399.6	384.49	125	34	70	140	44	90	170	55	110
45	470.3	455.17	125	34	70	140	44	90			
57	591.5	576.36	135	39	80	160	49	100	180	62	125
76	783.5	768.32	140	49	90	180	55	100			

1 1/2" x 1"

Z	d _e	d _p	Simplex			Duplex			Triplex		
			d _m	D ₁	A	d _m	D ₁	A	d _m	D ₁	A
30	379.5	364.5	130	39	85						
38	476.2	461.39	140	44	90	180	44	100	200	62	150
45	581.2	546.2	140	44	90						
57	706.5	691.63	160	44	100	200	54	110	200	62	150
76	936.9	921.98	170	44	100	220	54	120	250	69	150

Weiteres Verkaufsprogramm

Programme de vente supplémentaire

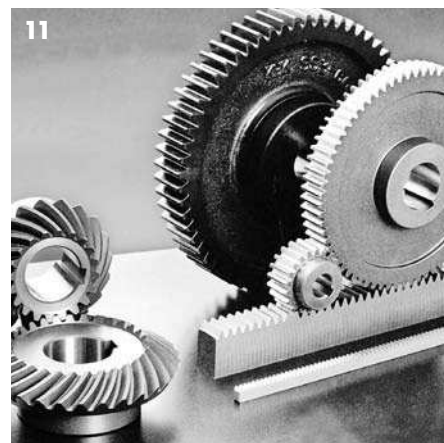
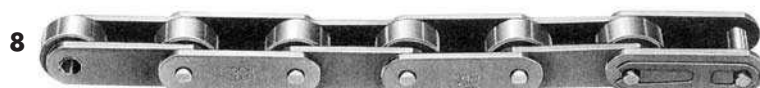
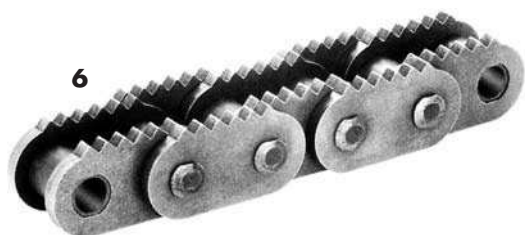
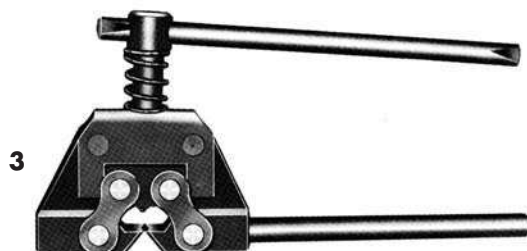
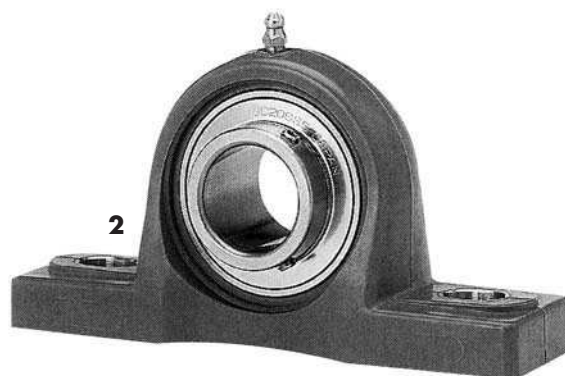
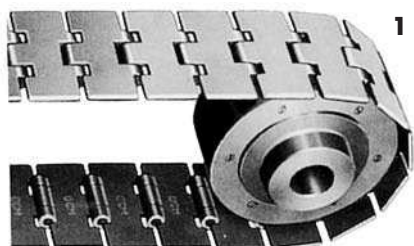

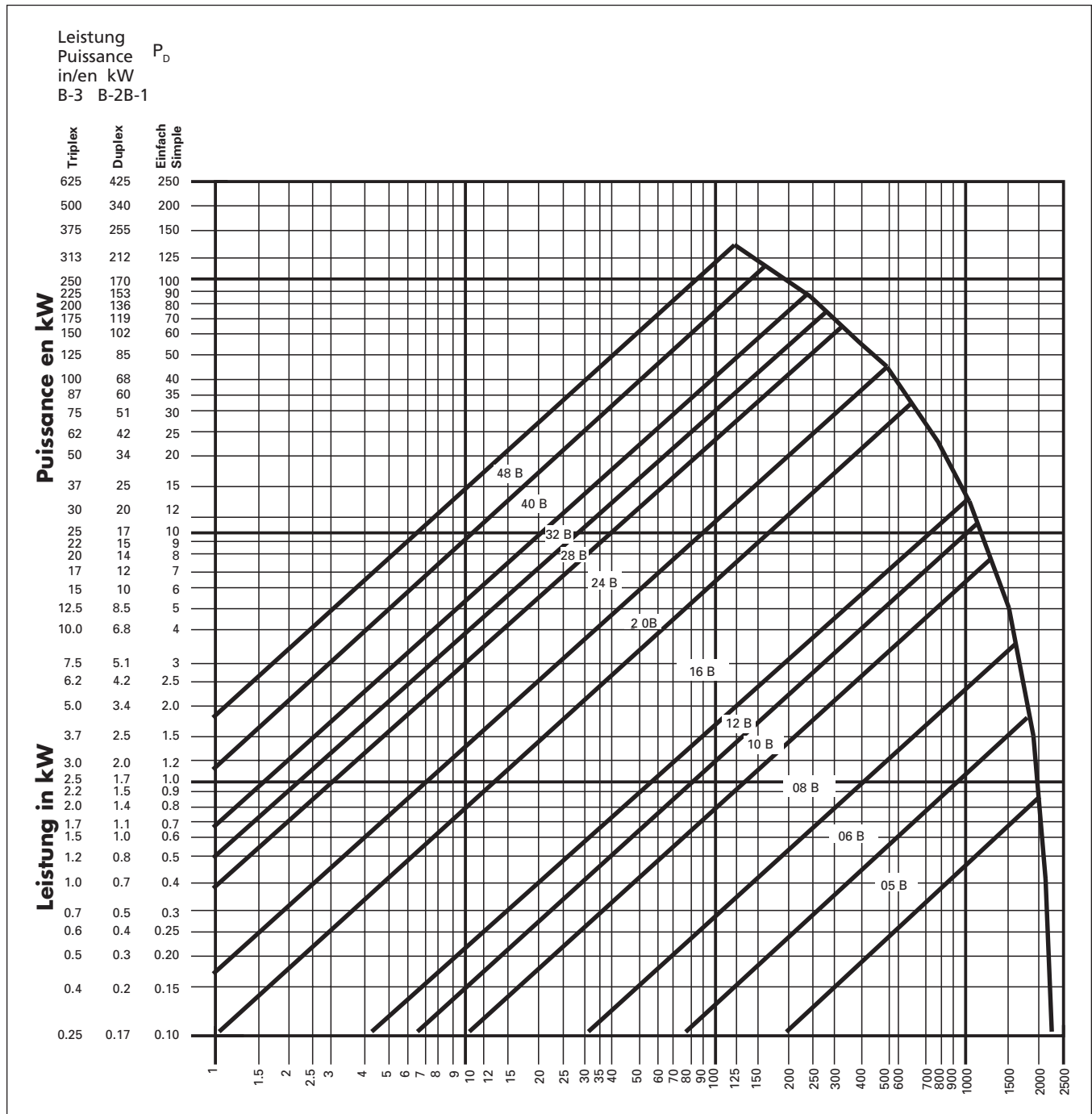

Drehzahl n_1 (U/min.) des kleinen Kettenrades (Ritzel)
Nombre de tours n_1 (tr/min.) de petite roue à chaîne (pignon)

Erläuterung der Auswahltafel

Die oberen Begrenzungslinien der Leistungsbereiche gelten für gleichförmige Belastungen, ohne Überlagerung dynamischer Kräfte, bei einem horizontalen Zweiwellen-Antrieb, mit dem kleinen Kettenrad (Ritzel von $z_1 = 19$ Zähne und eine Kettenlänge von 100 Gliedern bei einer Übersetzung von 3:1).

Die Lebensdauer beträgt etwa 15000 Betriebsstunden, wenn die Richtlinien auf Seite K-806 und K-807 sowie die entsprechende Schmierung aus obigem Diagramm beachtet werden.

Bei abweichenden Bedingungen ist die Antriebsleistung P mit den Faktoren f_1 und f_2 (siehe Seite K-801) zu multiplizieren. Mit dieser Leistungsgröße $P_D = P \cdot f_1 \cdot f_2$ wird die Kettenabmessung aus der Auswahltafel bestimmt.

Explication du tableau de sélection

Les lignes supérieures de délimitation des zones de puissance sont valables pour des charges uniformes, sans superposition de forces dynamiques, pour une transmission horizontale à deux arbres, avec la petite roue à chaîne (pignon) de $z_1 = 19$ dents et une longueur de chaîne à 100 maillons un rapport de 3:1.

En cas de lubrification recommandée (voir diagramme dessus) et d'observation des directives (voir pages K-806 et K-807), une durée de vie d'environ 15000 heures de service peut être attendue. Pour des conditions différentes, la puissance de transmission P doit être multipliée par les facteurs f_1 et f_2 (voir page K-801). La dimension de la chaîne est déterminée, avec cette grandeur de puissance $P_D = P \cdot f_1 \cdot f_2$ sur le tableau de sélection.

Allgemeine Verkaufsbedingungen

Conditions générales de vente



1. Angebote

Angebote werden freibleibend abgegeben. Sie entsprechen den Herstellungskosten am Tage der Angebotsabgabe. Preisänderungen bei Erhöhung der Selbstkosten bleiben vorbehalten. Irrtümer, wie Druck-, Schreib- und Rechenfehler, berechtigen uns zur Berichtigung.

2. Auftragserteilung

Die in den Drucksachen enthaltenen Unterlagen wie Mass- und Gewichtsangaben, Abbildungen und Beschreibungen sind Richtwerte. Eine Verbindlichkeit zur Benachrichtigung über erfolgte Änderungen besteht unsererseits nicht.

Muster werden gegen Berechnung geliefert. Modelle und Werkzeuge, die zur Ausführung eines Auftrages angefertigt werden, bleiben unser Eigentum, auch wenn Anteilkosten berechnet wurden.

Lieferbedingungen des Bestellers, die mit unseren Bedingungen in Widerspruch stehen, sind für uns unverbindlich, auch wenn sie der Bestellung zugrunde gelegt werden und wir dem Inhalt nicht widersprochen haben. Für Spezialanfertigungen müssen wir uns die Lieferung einer Mehr bzw. Mindermenge von bis zu $\pm 5\%$ des erteilten Auftragsumfanges vorbehalten.

3. Preise

Die Preise sind freibleibend und verstehen sich ab Lager Küssnacht, ohne MWST, Verpackung, Fracht und Porto.

4. Zahlungsbedingungen

Lieferung mit 30 Tagen Zahlungsziel ab Rechnungsdatum, ohne Skontoabzug. Sonderanfertigungen werden gegen $\frac{1}{3}$ Anzahlung in Arbeit genommen; $\frac{1}{3}$ der Kaufsumme wird vor Ablieferung fällig und der Restbetrag innert 30 Tagen ab Rechnungsdatum.

5. Lieferzeit

Die Lieferfristen sind unverbindlich. Überschreitungen berechtigen den Käufer nicht zum Rücktritt vom Kaufvertrag. Anspruch des Bestellers auf Entschädigung bei Lieferzeitüberschreitungen besteht nicht.

In Fällen höherer Gewalt oder durch Stilllegung der Lieferwerke – wegen Streik, Feuer oder anderer Störungen – kann die Ausführung der Bestellung eingestellt oder wenigstens teilweise aufgehoben werden.

6. Versand

Der Versand erfolgt auf Gefahr des Bestellers. Auf dem Transport abhanden gekommene oder beschädigte Waren werden von uns nur auf Grund einer neuen Bestellung gegen Berechnung der jeweils gültigen Preise ersetzt.

Abweichungen vom Lieferschein oder von der Rechnung sind uns unverzüglich, spätestens innert 8 Tagen nach Erhalt der Sendung schriftlich anzuzeigen.

7. Rücknahme

Speziell angefertigte oder vom Kunden weiterbearbeitete Erzeugnisse können nicht zurückgenommen werden. Neuwertige Standardartikel werden bei vorheriger Avisierung zurückgenommen und gutgeschrieben unter Abzug der gebahnten Spesen.

8. Garantie

Der Lieferant gewährt dem Besteller auf alle Teile eine Garantie von einem Jahr, bei durchgehendem Dauerbetrieb für die Dauer von 6 Monaten, ab Rechnungsdatum. Im Rahmen dieser Garantie verpflichtet sich der Lieferant, auf schriftliche Aufforderung des Bestellers hin alle Teile, die nachweisbar infolge Material- und Bearbeitungsfehlern mangelhaft sind, nach seiner Wahl auszubessern oder zu ersetzen.

Von der Garantie ausgeschlossen sind Schäden infolge natürlicher Abnutzung, mangelhafter Wartung, Missachtung von Betriebsvorschriften, übermässiger Beanspruchung, ungeeigneter Betriebsmittel, chemischer oder elektrolytischer Einflüsse, mangelhafter, nicht vom Lieferanten ausgeführter Bau- und Montagearbeiten sowie infolge anderer Gründe, die der Lieferant nicht zu vertreten hat.

Jede weitere Gewährleistungspflicht des Lieferanten, insbesondere auf Schadensersatz und Auflösung des Vertrages, ist wegbedungen.

9. Gerichtsstand: Küssnacht ZH

1. Offres

Les offres sont faites sans engagement. Elles correspondent au prix de revient le jour de l'envoi de l'offre. Les modifications de prix, en cas d'augmentation du prix de revient, restent réservées. Nous nous réservons le droit de rectifier les fautes éventuelles d'impression, d'écriture ou de calcul.

2. Transmission d'ordres

Les documents contenus dans les imprimés tels que les indications de mesures et de poids, les illustrations et les descriptions sont des valeurs indicatives. Nous ne sommes pas obligés de faire part des modifications intervenues.

Les échantillons sont livrés contre facture. Les modèles et les outils qui ont servi à l'exécution d'une commande restent notre propriété, même si leur coût partiel a été facturé.

Les conditions de livraison du client qui sont en opposition avec les nôtres ne nous lient en aucune façon, même si elles ont à la base de la commande et que nous ne les ayons pas contestées. Pour les fabrications spéciales, nous devons nous réserver un droit de livraison de $\pm 5\%$ par rapport à la quantité commandée.

3. Prix

Les prix sont sans engagement et s'entendent départ Küssnacht, sans TVA, emballage ni transport et port.

4. Conditions de paiement

La livraison se fait contre paiement à 30 jours dès la date de la facture, sans déduction d'escompte. Les fabrications spéciales sont acceptées après réception d'un acompte d'un tiers. Un tiers de la somme totale est échu au moment de la livraison et le solde dans les 30 jours dès la date de la facture.

5. Délais de livraison

Les délais de livraison sont sans engagement. Les dépassements n'autorisent pas l'acheteur à résilier le contrat d'achat. Ce dernier ne peut prétendre à aucune indemnité en cas de dépassement du délai de livraison. En présence d'événements imprévus, tels que cas de force majeure, guerre, révolution, incendie, prescriptions gouvernementales, nous nous réservons le droit de nous départir totalement ou partiellement des obligations de livraison.

6. Expédition

L'expédition se fait aux risques et périls de l'acheteur. Les marchandises perdues ou abîmées durant le transport ne sont remplacées par nous que s'il est passé une nouvelle commande contre facture au prix du jour.

Toutes dérogations au bulletin de livraison ou à la facture doivent nous être annoncées sans retard, au plus tard dans les 8 jours après réception de l'envoi.

7. Marchandises en retour

Les fabrications spéciales, de même que les produits qui ont été usinés ultérieurement par le client ne sont pas repris. Les articles standards, à l'état de neuf sont repris moyennant avis préalable et crédités sous déduction des frais occasionnés.

8. Garantie

Sur toutes les pièces, le fournisseur accorde au commettant une garantie d'une année, resp. de 6 mois en cas d'exploitation ininterrompue, à compter de la date de la facture. Dans le cadre de cette garantie, le fournisseur s'engage, suite à la demande écrite du commettant, à réparer ou à remplacer à son propre choix toutes les pièces visiblement défectueuses par suite de défauts de matériel, de fabrication ou d'usage.

Sont exclus de la garantie les dommages dus à une usure normale, à un défaut de maintenance, à l'inobservation des instructions de service, à des sollicitations exagérées, à des moyens d'exploitation impropres, à des influences chimiques ou électrolytiques, à des travaux de construction ou de montage erronés non effectués par fournisseur, ainsi qu'à d'autres raisons analogues non imputables au fournisseur.

D'autres exigences de garantie envers le fournisseur, en particulier pour des dommages-intérêts, sont expressément exclues.

9. For: Küssnacht ZH

H. FRÖHLICH AG^{TEC}

H. FRÖHLICH AG · Industrietechnik
Widenholzstrasse 1 · CH-8304 Wallisellen
Tel. +41 44 910 16 22 · Fax +41 44 910 63 44
info@h-froehlich-ag.ch · www.h-froehlich-ag.ch